

INSTRUCTION SHEET FOR JIMS® FAT 5 SPEED OVERDRIVE



**INSTRUCTIONS FOR THE FOLLOWING PART NO'S:
8280, 8279, 8282, 8283, 8284, 8273, 8274, 8275**

These instructions are for installation of both Super Kit or complete transmission, for EVO or Twin Cam. These instructions are also reference for disassembly. Disassembly is the same as assembly, but in reverse order.

READ ALL INSTRUCTIONS BEFORE PERFORMING WORK! IF YOU DO NOT KNOW WHAT YOU ARE DOING, DO NOT DO IT!

No information in this instruction sheet pertaining to motorcycle repair is represented as fool-proof or even altogether safe. Some people can ruin a mechanic's vise with a tack hammer. Even something safe, done incorrectly or incompletely can and will backfire. You are responsible for the safety of your work and knowledge of the tools, repair equipment, components, methods and concepts needed to complete these tasks. You must carefully and systematically perform each and every step safely. All information listed in this instruction sheet has been tested, re-tested and used daily in JIMS Research and Development Department.

JIMS® IS NOT RESPONSIBLE FOR THE QUALITY AND SAFETY OF YOUR WORK!

If you are not sure about any of the procedures in these instructions, have a reputable H.D. repair shop perform these procedures for you.

WARNING: Always disconnect the battery ground cable (at the battery) to prevent injury. Your work area should be well lit. Wear safety glasses (over your eyes) and protective clothing when working around power tools and compressed air. Be careful with chemicals when cleaning parts. Protect your skin from solvents and use only in a well-ventilated area. Degreasers are flammable and are a fire hazard. Just use common sense and exercise good judgement.

**CAUTION: WEAR SAFETY GLASSES. EXCESSIVE FORCE MAY DAMAGE PARTS!
SEE JIMS® CATALOG FOR HUNDREDS OF TOP QUALITY PROFESSIONAL TOOLS.
THE LAST TOOLS YOU WILL EVER NEED TO BUY.**

Performance Parts For Harley-Davidson Motorcycles

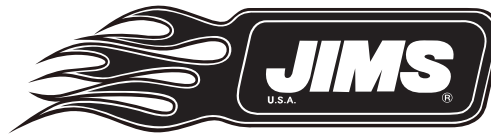

INSTRUCTION SHEET FOR JIMS® FAT 5 SPEED OVERDRIVE

Instructions for preparing the Transmission Case to install JIMS® Fat 5 Super Kit:

Refer to your Service Manual and parts book for the proper year and model you will be installing this kit into for reference. Also, use a Late H.D.® 2002- Present Big Twin Service Manual and parts book for reference.

1. Remove Old Gear set and all Case Bearings per H.D.® Service Manual.

NOTE: If Dowel Pin H.D.® No. 634 came out upon the Gear Set removal, it will need to be reinstalled back into the Trans Case. Refer to your H.D.® Service Manual.

2. Upgrade Shifter Shaft Bushing for 1990-99 Big Twins and 1999-2000 T/C FLHT, FXR & FXD by removing the existing Shifter Shaft Bushing and installing a new longer Shifter Shaft Bushing (Sleeve) JIMS No. 7514 (supplied in this kit). Follow the instruction Sheet provided with JIMS Tool No.1664 (not included) and refer to any 2000 to 2005 B.T. H.D. Service Manual for Shifter Shaft Assembly.

3. Using masking tape, cover all the trap door flat holes except for the top three. The two threaded holes at the top of the trap door flange are used for mounting of the drill plate and the shift fork shaft hole (center thru hole) is used as the pilot for the drill bits.

4. From inside the transmission case, tape over all bores as follows:
 - Vehicle speed sensor and mounting screw bores
 - Transmission top cover and shifter drum support screw bores
 - Transmission drain hole bore

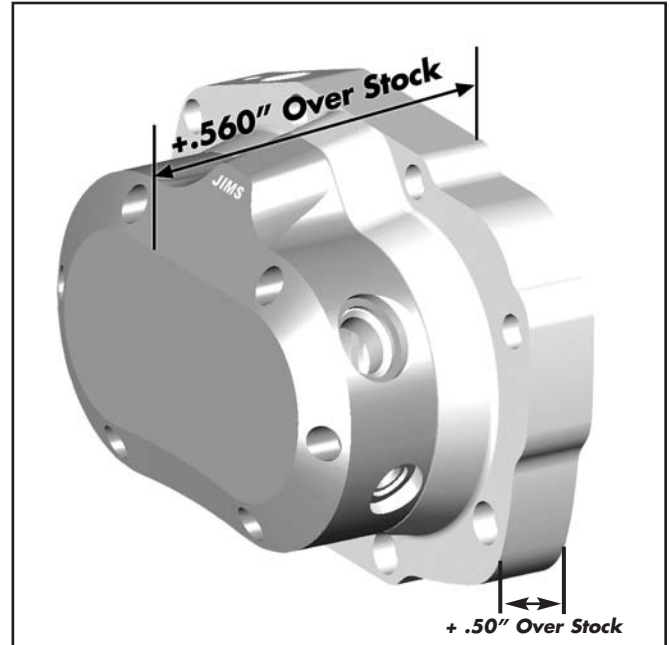

Special Tools Required to install JIMS® Fat 5 Super Kit:	
<i>Note: Some tools are the same as any 5 speed installation tools you might already have.</i>	
Part No.	Description
35316-80	5-speed Main Drive Gear Tool
34902-84	Mainshaft Bearing Race Tool
94660-37A	Mainshaft Sprocket Locknut Wrench
2260	Big Twin Sprocket Locker
1131	Small Lock Ring Pliers
1133	Large Lock Ring Pliers
1720	5-speed Main Bearing Remover
1102	Solvent 184
1080	Brass Hammer
1289	Trans Stand
1145	Modular Engine & Transmission Stand Kit
2256	Main Drive Gear Seal Protector
1664	Shifter Sleeve Tool

**CAUTION: WEAR SAFETY GLASSES. EXCESSIVE FORCE MAY DAMAGE PARTS!
SEE JIMS® CATALOG FOR HUNDREDS OF TOP QUALITY PROFESSIONAL TOOLS.
THE LAST TOOLS YOU WILL EVER NEED TO BUY.**

Performance Parts For Harley-Davidson Motorcycles

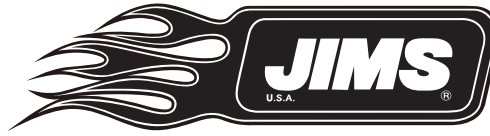

INSTRUCTION SHEET FOR JIMS® FAT 5 SPEED OVERDRIVE

- Main Drive gear bearing bore
- Countershaft needle bearing bore
- Fork shaft bore
- Shifter shaft bore

Warning: Be sure drill plate is properly oriented before drilling. Improper orientation will result in damage that requires replacement of the transmission case.

Special parts needed to install JIMS® Fat 5 Super Kit:	
Part No.	Description
1231	Gear oil
8042K	Speedo Block-Off Plate (Depending on application)
1708	Mega Nut
8126	Speedo Re-Calibration Module (Depending on year, pulley & tire size)

4. Fasten drill plate, JIMS® No.8357 to the top of the trap door flange using old and new speed sensor mounting screws as shown in *Figure 1*.
5. Spread one or two clean shop cloths inside the trans case to catch the metal shavings and debris.
6. Starting with a 3/8-inch drill bit, alternately use progressively larger bits to enlarge the fork shaft hole. Finish the drilling operation with a 3/4-inch drill bit.
7. Remove all remaining material up to the edge of the drill plate with a die grinder or similar tool. Remove the drill plate once complete.
8. Using emery cloth, steel wool, or a fine tooth file; remove any burrs or ridges that may exist from the drilling or cutting operations.

Warning: Abrasive particles can damage machined surfaces and result in premature failure.

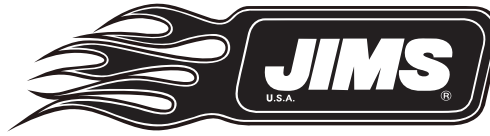

FIGURE 1

9. Carefully pull out shop cloths from inside the trans case. Exercise care to keep any debris captured by the cloths from falling into the trans case.
10. Place drain pan beneath trans case and remove tape from drain hole. Thoroughly flush the trans case with a non-volatile cleaning solution or solvent to remove any metal shavings, dust or debris that might remain. For best results, use a squirt bottle to direct as stream of solvent through the trans top cover opening. Repeat procedure as necessary draining excess solvent through the drain hole using low-pressure compressed air to thoroughly blow out all solvent.

**CAUTION: WEAR SAFETY GLASSES. EXCESSIVE FORCE MAY DAMAGE PARTS!
SEE JIMS® CATALOG FOR HUNDREDS OF TOP QUALITY PROFESSIONAL TOOLS.
THE LAST TOOLS YOU WILL EVER NEED TO BUY.**

Performance Parts For Harley-Davidson® Motorcycles



INSTRUCTION SHEET FOR JIMS® FAT 5 SPEED OVERDRIVE

11. Using a clean lightly oiled cloth **, thoroughly wipe the Inside of the transmission case. Repeat this step with a new cloth until the cloth comes out clean.
12. Carefully inspect the transmission case for any metal shavings or debris. Repeat steps 11 through 13 if any debris is found.
13. Remove the masking tape to uncover remaining holes and bores.
14. Thoroughly inspect each bore for any metal shavings, dust or debris. Alternately direct compressed air into each bore to be certain that it is clean and dry.

INSTRUCTIONS FOR PREPARING THE TRANSMISSION TOP COVER TO CLEAR THE NEW SHIFTING LEVER WHEN INSTALLING JIMS FAT 5 SUPER KIT INTO ANY 1990-99 BIG TWINS AND 1999-2000 T/C FLHT, FXR & FXD MODELS:

NOTE: 2000-Present FXST and 2001-Present FLHT & FXD models do not need modifying.

1. Place new top cover gasket JIMS® No.34904-87 on the trans top cover flange.
2. Use 4 of your top cover screws to hold gasket in place by slipping screws thru the gasket and into the top cover.
3. Mark the inside exposed portion of the flange as shown in *Figure 1*. The material to be removed is .060 wide by 1.80 Deep. Remove top cover screws and gasket.
4. With a die grinder tool, remove the casting rib until it is the same height as the adjacent surface area. Clean the top cover of all loose material, including screw holes as shown in *Figure 1*.
5. With shifter assembly installed in transmission; Install top cover with gasket using only 2 screws (so cover can move if shifter arm is making contact with top cover).
6. While watching to see if the top cover moves forward, shift the transmission into first gear firmly holding the shift lever down. If there is no forward movement of the top cover, then the modification is complete. If any forward movement (of top cover) is observed, then more of the casting rib must be removed. Repeat Step 4 as necessary.

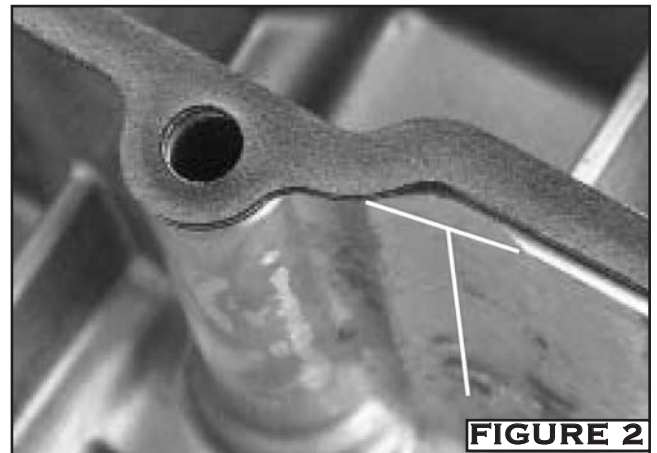

**CAUTION: WEAR SAFETY GLASSES. EXCESSIVE FORCE MAY DAMAGE PARTS!
SEE JIMS® CATALOG FOR HUNDREDS OF TOP QUALITY PROFESSIONAL TOOLS.
THE LAST TOOLS YOU WILL EVER NEED TO BUY.**

Performance Parts For Harley-Davidson Motorcycles

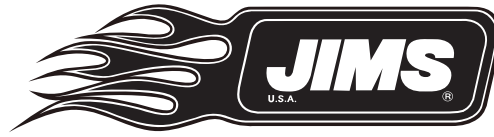

INSTRUCTION SHEET FOR JIMS® FAT 5 SPEED OVERDRIVE

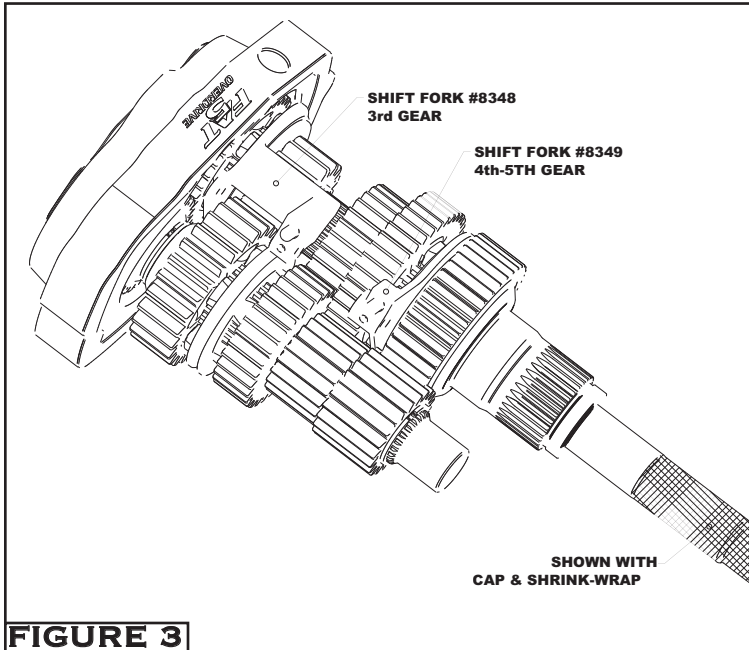

Instructions for Installing JIMS® Fat 5 Super Kit parts into case:

1. Install main drive gear bearing JIMS® No. 8996 using JIMS® Tool No. 35316-80. Follow the instruction, sheet provided with tool or refer to your H.D.® Service Manual.

NOTE: NEVER install any bearings into the case by applying pressure to the inner race. Doing so will destroy the bearing. Do not remove the mainshaft protective cover (Figure 4) on the clutch hub spline end of mainshaft. It can be removed after Super Kit has been installed into the trans case.

2. Install the new main drive gear retaining ring, JIMS® No. 11061 (supplied in this Kit) with the bevel facing out. Refer to your H.D.® Service Manual.
3. Install new main seal JIMS® No.12067A (supplied in this kit) with JIMS® Tool No. 95660-85 to use with JIMS® Tool No. 95660-42. Refer to your H.D.® Service Manual.
4. Install main drive gear JIMS® No. 8339-2, using JIMS® Tool No. 35316-80. Follow the instruction sheet provided with tool or refer to your H.D.® Service Manual.
5. Install counter shaft end bearing JIMS® No. 8977. Refer to your H.D.® Service Manual. **NOTE: Install counter shaft bearing by applying pressure to the LETTER side of**

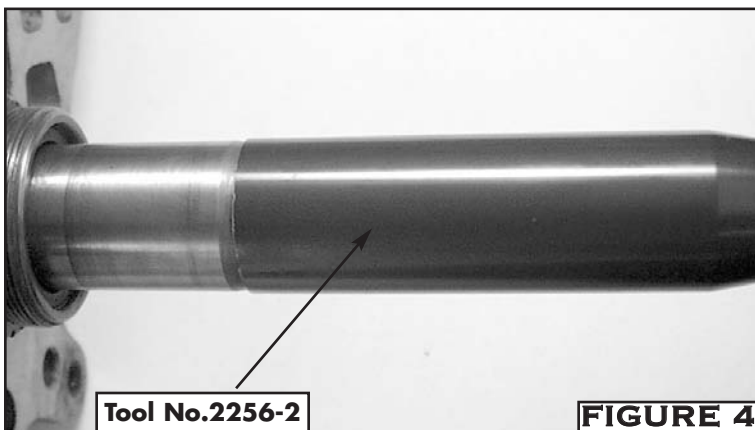

bearing ONLY.

6. Install shifter shaft seal JIMS® No. 12045 (supplied in this kit). Refer to your H.D.® Service Manual.
7. Install shifter assembly JIMS® No. 8325 (supplied in this kit). Refer to your Late H.D.® Service Manual.

**CAUTION: WEAR SAFETY GLASSES. EXCESSIVE FORCE MAY DAMAGE PARTS!
SEE JIMS® CATALOG FOR HUNDREDS OF TOP QUALITY PROFESSIONAL TOOLS.
THE LAST TOOLS YOU WILL EVER NEED TO BUY.**

Performance Parts For Harley-Davidson® Motorcycles

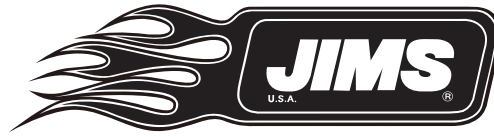

INSTRUCTION SHEET FOR JIMS® FAT 5 SPEED OVERDRIVE

8. Install shifter shaft washer JIMS® No. 6497HW and retaining ring JIMS® No. 11150 (supplied in this kit). Refer to your late H.D.® Service Manual.

9. Install shifter shaft centering pin (BOLT) JIMS® No. 34978-00A (supplied in this kit). Torque to 10 ft-lb. Refer to your Late H.D.® Service Manual.

Caution: Center shifter assembly return spring on each side of centering bolt.

NOTE: This model will not require any gear engagement adjustments. Refer to your Late H.D.® Service Manual.

NOTE: 2 of the 3 shift forks will need to be installed into their shift rings as indicated in Figure 3.

10. Place 3rd gear fork, JIMS® No. 8348 into 3rd gear shift ring, JIMS® No. 8342 at the same time sliding both the fork and shift ring away from trap door so the fork will lay down towards countershaft as shown in *Figure 3*.

11. Place 4th gear fork, JIMS® No. 8349 into 4th and 5th gear shift ring, JIMS® No. 8354 at the same time allowing fork to lay down towards countershaft as shown in *Figure 3*.

Note: The last fork for 1st and 2nd gear, JIMS® No. 8347, is installed after the Super Kit has been installed into case.

12. Place trap door gasket JIMS® No. 8352 over the two dowel pins on the trans case. Refer to your Late H.D.® Service Manual.

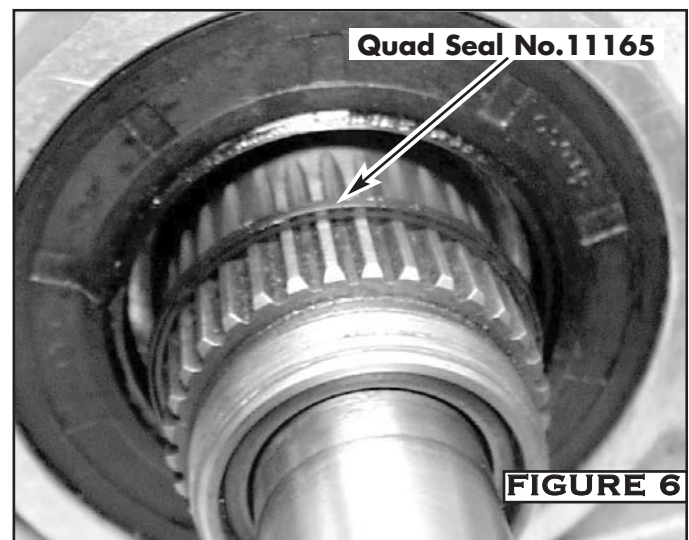
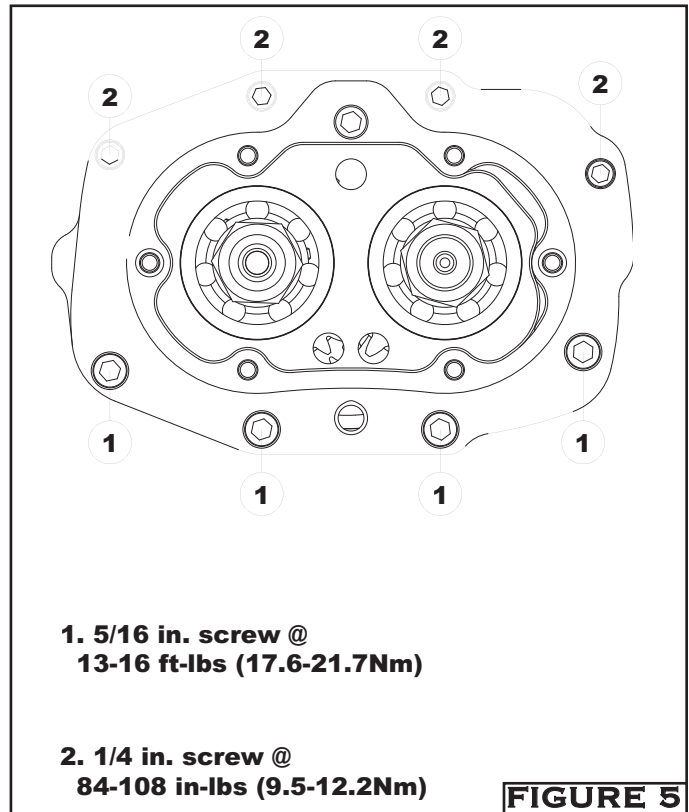

**CAUTION: WEAR SAFETY GLASSES. EXCESSIVE FORCE MAY DAMAGE PARTS!
SEE JIMS® CATALOG FOR HUNDREDS OF TOP QUALITY PROFESSIONAL TOOLS.
THE LAST TOOLS YOU WILL EVER NEED TO BUY.**

Performance Parts For Harley-Davidson Motorcycles

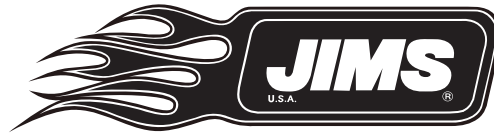

INSTRUCTION SHEET FOR JIMS® FAT 5 SPEED OVERDRIVE

13. Apply a small amount of ** lube to the inside of the main drive gear.

NOTE: If you have removed the mainshaft protective cover already, install a lubed tool JIMS® No. 2256-2 main drive gear seal protector inside the main drive gear seal. The mainshaft protective sleeve covering the clutch hub spline on the mainshaft can also be used as a seal protector as the mainshaft is being installed thru the main drive gear as shown in Figure 4.

14. Gently place the gear set (trap door assembly) into the case by sliding the mainshaft through the main drive gear bearing and slowly pushing the trap door assembly inward until the trap door makes contact with the two dowel pins in trans case. A non-marring hammer is helpful to tap the trap door assembly over the dowel pins without risking damage to the aluminum/chrome of the trap door assembly. Apply a small amount of lube ** or Blue Loctite to each of the four 1/4" screws, JIMS® No. 1258 and thread them into the top four 1/4" screw holes. Torque to 84-108 in-lbs. in a criss-cross pattern. Apply a small amount of lube ** or Blue Loctite to each of the four 5/16" screws, JIMS® No. 1118 and thread them into the four 5/16" screw holes. Torque to 13-16 ft-lbs in a criss-cross pattern as shown in Figure 5.

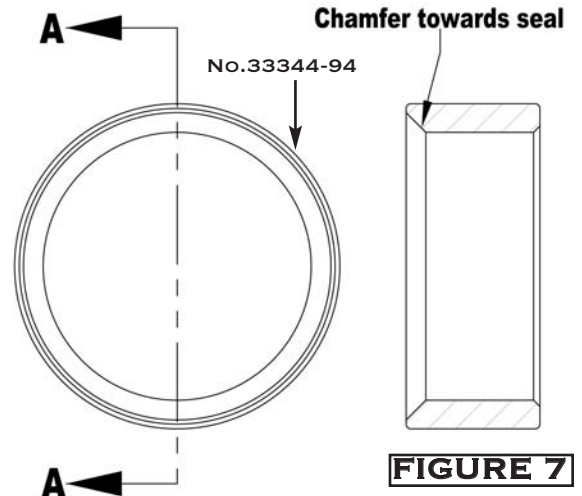

**CAUTION: WEAR SAFETY GLASSES. EXCESSIVE FORCE MAY DAMAGE PARTS!
SEE JIMS® CATALOG FOR HUNDREDS OF TOP QUALITY PROFESSIONAL TOOLS.
THE LAST TOOLS YOU WILL EVER NEED TO BUY.**

Performance Parts For Harley-Davidson Motorcycles

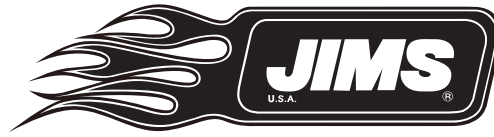

INSTRUCTION SHEET FOR JIMS® FAT 5 SPEED OVERDRIVE

Instructions for installing the 1st and 2nd Gear Shift Fork JIMS® No. 8347

1. Place the final remaining shift fork for the 1st and 2nd gear, JIMS® No. 8347 into fork slot of 1st and 2nd shift ring, JIMS® No. 8341 putting it down through the top cover opening and slide it into the shift ring.
2. Slide shift fork shaft, JIMS® No. 34088-87 (supplied in this kit) through the hole in the trap door, all three shift forks and into the left side of trans case. Refer to your late H.D.® Service Manual.
3. Install shifter shaft set screw, JIMS® No. 3784C (supplied in this kit). Tighten until you have about .020 end- play on the shifter shaft.

Instructions for Installing Main Seal Spacer and Torquing Mainshaft Nuts on Primary Side:

1. Slide all three shift rings so that they all three engage into matting gears (this is to lock the trans) to keep the gears from turning.
2. Install mainshaft quad seal, JIMS® No. 11165 ** (supplied in this kit) over the main drive gear on left side of trans as shown in *Figure 6*.

NOTE: Spacer 33344-94 is for late pulley only, pulley REFERENCE No. 40250-94A

3. Install mainshaft seal spacer JIMS® No. 33344-94 ** (supplied in this kit) over mainshaft bearing boss on left side of trans, with the chamfered side to the inside towards seal as shown in *Figures 7 and 8*.
4. Install the drive pulley you will be using. Refer to your H.D.® Service Manual.
5. To install Mega Nut JIMS® No. 1708 (not supplied in this kit) over the main drive gear. Follow instruction sheet supplied with Mega Nut.
6. Install center pushrod, JIMS® No. 37088-85 (supplied in this kit). Lube ** both ends and slide pushrod into Mainshaft.
7. Install primary drive, refer to your H.D.® Service Manual for the model your installing this kit into.

Special Tools Required to un-install JIMS® Fat 5 Super Kit:	
<i>Note: Some tools are the same as any 5 speed installation tools you might already have.</i>	
Part No.	Description
1077	Door Puller
35316-80	5-speed Maindrive Gear Tool
34902-84	Mainshaft Bearing Race Tool
94660-37A	Mainshaft Sprocket Locknut Wrench
38515-90	Clutch Spring Compressor Tool 1990 - 1997
2260	Big Twin Sprocket Locker
1131	Small Lock Ring Pliers
1133	Large Lock Ring Pliers
2362	External Lock Ring Pliers
997	Maindrive Gear Bearing Tool
2234	Primary drive Locking Tool
1720	5-speed Main Bearing Remover
2189	Main and Counter Shaft Installer
1102	Solvent 184
1080	Brass Hammer
1289	Trans Stand
1145	Modular Engine & Transmission Stand Kit

**CAUTION: WEAR SAFETY GLASSES. EXCESSIVE FORCE MAY DAMAGE PARTS!
SEE JIMS® CATALOG FOR HUNDREDS OF TOP QUALITY PROFESSIONAL TOOLS.
THE LAST TOOLS YOU WILL EVER NEED TO BUY.**

Performance Parts For Harley-Davidson Motorcycles

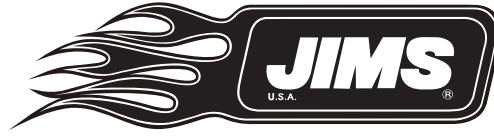

INSTRUCTION SHEET FOR JIMS® FAT 5 SPEED OVERDRIVE

Instructions for installing shift drum, pillow blocks and top lid:

1. Place the shift drum assembly with pillow blocks over the 3 Pins of shift forks (you may need to move forks as needed to line up with the tracks in the shift drum). At the same time aligning the pillow blocks over and onto the 4 split dowel pins. Refer to your Late H.D.® Service Manual.
2. Install four 1/4" pillow block mounting washers, JIMS® No. 1215 over the four 1/4" pillow block mounting screws, JIMS® No. 2135. Apply a small amount of lube ** or Blue Loctite to each screw and torque to 7-9 ft-lbs. in a criss-cross pattern. Refer to your late H.D.® Service Manual.
3. Install top cover gasket; JIMS® No. 34904-86 (supplied in this kit) per your H.D.® Service Manual.
4. Install your top cover (Lid) with your mounting hardware; refer to your H.D.® Service Manual.
5. Install vent hose, H.D.® part No. 42533-91A (not supplied in this kit) to your top cover elbow fitting. Refer to your H.D.® Service Manual.

Instructions for installing end cover:

1. Install right push rod for clutch; JIMS® No. 8076 (supplied in this kit).
2. Install end cover, JIMS® No. 8329 (supplied in this kit) with gasket JIMS® No. 8352 (supplied in this kit). Refer to your H.D.® Service Manual.
3. Install speed sensor into trap door if applicable.
NOTE: If you will be running an electronic speed sensor you will need to place a sensor cover, (see special parts list) over your sensor hole in trans case and install your electronic speed sensor into the trap door using your favorite gasket sealer. If you will not be using an electronic speed sensor in either location (trap door or case) you will need to order a speed block-off plate for the trap door.
4. Install speedo block-off plate, JIMS® No.8042K.
5. Install speedo block-off plate mounting screw, JIMS® No. 1120 by applying a small amount of lube ** or Blue Loctite to screw and torque to 7-9 ft-lbs.
6. Fill trans with H.D.® trans lube or equivalent, to the same level as a 5 speed trans. Refer to your H.D.® Service Manual for reference.

In the unlikely event that you would need to disassemble this trans, you will need a few of JIMS® Service Tools. For replacement parts, see materials list on page 9.

WARNING: Always disconnect the battery ground cable (at the battery) to prevent injury.

Instructions for disassembly of your Fat 5 Speed Overdrive:

This kit is basically easy to disassemble, but does require some special tools (See tool list on page 8.)

**CAUTION: WEAR SAFETY GLASSES. EXCESSIVE FORCE MAY DAMAGE PARTS!
SEE JIMS® CATALOG FOR HUNDREDS OF TOP QUALITY PROFESSIONAL TOOLS.
THE LAST TOOLS YOU WILL EVER NEED TO BUY.**

Performance Parts For Harley-Davidson Motorcycles

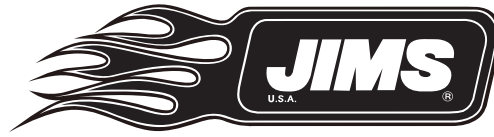
**INSTRUCTION SHEET FOR JIMS® FAT 5 SPEED OVERDRIVE**

1. Remove primary's and clutch components as indicated in your H.D. Service Manual.
2. Drain oil from trans by removing drain plug from trap door, JIMS No. 739A (or if your trans case has other means of oil drain use that.)
3. Remove end cover. Refer to your H.D. service manual.
4. Remove top cover and shift drum; slide all three forks into any gear (this is to lock the trans), to keep the gears from turning for removal of mainshaft and counter shaft nuts.
5. Remove shifter shaft set screw, JIMS® No. 3784C.
6. Remove shifter shaft, JIMS® No. 34088-87.
7. Remove 1st and 2nd gear shift fork JIMS® No. 8347.
8. Remove all trap door hardware, holding door to trans case.
9. Slide the 3rd gear shift fork & shift ring and 4th-5th gear shift fork & shift ring away from the trap door so that the forks will lay down towards the countershaft. (As shown in *Figure 3*)
10. Install trap door puller Tool, JIMS® No. 1077 by lubing ** all threads of tool and threading trap door puller tool onto trap door.
11. Remove trap door slowly making sure shift forks clear case.
12. Remove both trap door bearings as you would for any 5-speed rebuild.
13. Remove all gears from main and counter shafts as you would for any 5-Speed trans following the parts list as laid out in this instruction sheet.
14. Remove any other parts, (bearings and seals) from trans case as you would for any 5-Speed.
15. To service main drive gear, use JIMS® tool No. 997.

**CAUTION: WEAR SAFETY GLASSES. EXCESSIVE FORCE MAY DAMAGE PARTS!
SEE JIMS® CATALOG FOR HUNDREDS OF TOP QUALITY PROFESSIONAL TOOLS.
THE LAST TOOLS YOU WILL EVER NEED TO BUY.**

Performance Parts For Harley-Davidson Motorcycles

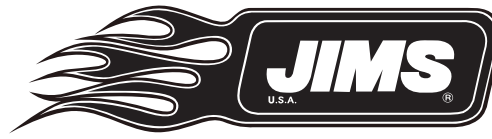

INSTRUCTION SHEET FOR JIMS® FAT 5 SPEED OVERDRIVE

Parts List:			
No.	Qty	Part No.	Description
1	1	8325	Shift Lever, w/springs
2	1	8326	Screw, Adjuster, Clutch Hub
3	3	8873*	Ball Bearing, Ramp
4	1	8876A	Split Bearing, Mainshaft & Countershaft
5	1	8327	Trap Door, Fat 5
6	1	8343-1	Spline Sleeve, 4th & 5th, mainshaft
7	1	8329	End Cover, Chrome, Fat 5
8	1	8330-1	Mainshaft, Fat 5
9	1	8331-1	Countershaft W/5th Gear
10	2	8081	Thrust Washer, Mainshaft & Countershaft
11	1	8332-1	Gear, 2nd, Mainshaft
12	1	8333-1	Gear, 1st, Countershaft
13	4	8334-1	Gear, 1st, Mainshaft
14	1	8335-1	Gear, 2nd, Countershaft
15	1	8336-1	Gear, 3rd, Mainshaft
16	1	8337-1	Gear, 3rd, Countershaft
17	1	8338-1	Gear, 5th, Mainshaft
18	1	8339-2	Gear, 4th, Mainshaft
19	1	8340-1	Gear, 4th, Countershaft
20	1	8341-1	Shift ring, 1st & 2nd, Countershaft
21	1	8342-1	Shift Ring, 3rd, Mainshaft
22	1	8328-1	Spline Sleeve, 1st & 2nd, C/S
23	1	8344-1	Spline Sleeve, 3rd, M/S
24	2	35078-79	Locknut, Mainshaft & Countershaft
25	1	8996	Bearing, Main Case
26	2	8992A	Bearing, Trap Door
27	5	11067	Retaining Ring
28	1	34979-00	Sleeve, Shifter Shaft
29	1	34978-00A	Centering Pin
30	1	8076	Pushrod, Clutch, Right
31	1	8977	Crankshaft Bearing, Closed End
32	2	8345	Main Drive, Needle Bearing
33	4	1258	Screw, Upper Trap Door
34	4	1118	Screw, Upper Trap Door
36	1	8347	Shift Fork, 1st & 2nd Gear
37	1	8348	Shift Fork, 3rd Gear
38	1	8349	Shift Fork, 4th & 5th Gear
39	1	12067A	Seal, Main Case
40	1	34088-87A	Shaft, Shift Fork

Parts List:			
No.	Qty	Part No.	Description
41	1	8350	Shift Drum
42	1	8351	Gasket, End Cover
43	1	8352	Gasket, Trap Door, Stock Cover
44	4	8353	Bearing Pack, Mainshaft & Countershaft
45	1	34091-85	Bearing, Inner Race
46	1	6003	Thrust Washer
47	1	33904-00	Neutral Switch
48	1	8354	Shift Ring, 4th & 5th, Mainshaft
49	1	37088-85	Pushrod, Center
50	2	35087-99	Retaining Ring, Trap door
51	1	33304-00	Assy, Right Pillow Block
56	1	33301-00A	Assy, Left Pillow Block, W/Bearing & Retainer
57	1	11342	Retainer, Shift Drum
58	4	2135	Screw, Pillow Block
59	1	34904-86	Gasket, Top Cover
60	1	25604-00*	Ramp, Inner
61	1	25605-00*	Ramp, Outer
62	1	10998	Retaining Ring
63	1	34920-86*	Coupler Clutch
64	1	2226*	Clutch Bearing
68	1	72405-98TN	Assembly, Tan Wire
69	1	72405-98BK	Assembly, Black Wire
70	1	72241-94A	Terminal, 1/4" Ring, 14-18 GA.
71	1	70585-93	Connector (18-20)
72	6	1121	Screw, Chrome
73	1	12045	Seal, Shifter
74	1	6497H	Washer, Shifter
75	1	11150	Retaining Ring, Shifter
76	1	12035B	Seal, Gear, Main Drive
78	6	8356	Pin, Drum
79	1	11165	Quad Seal
80	1	739A	Drain Plug, Magnetic
81	1	3784C	Plug, Shifter Shaft
82	1	11161	Retaining Ring, Main Drive Gear
83	1	37075-87	Dipstick With O-Ring #11132
88	1	8357	Tool, Modification, Case
89	4	1215	Washer, Pillow Block
90	1	8273-IS	Instruction Sheet

*NOT INCLUDED IN SUPER KITS.

**CAUTION: WEAR SAFETY GLASSES. EXCESSIVE FORCE MAY DAMAGE PARTS!
SEE JIMS® CATALOG FOR HUNDREDS OF TOP QUALITY PROFESSIONAL TOOLS.
THE LAST TOOLS YOU WILL EVER NEED TO BUY.**

Performance Parts For Harley-Davidson® Motorcycles

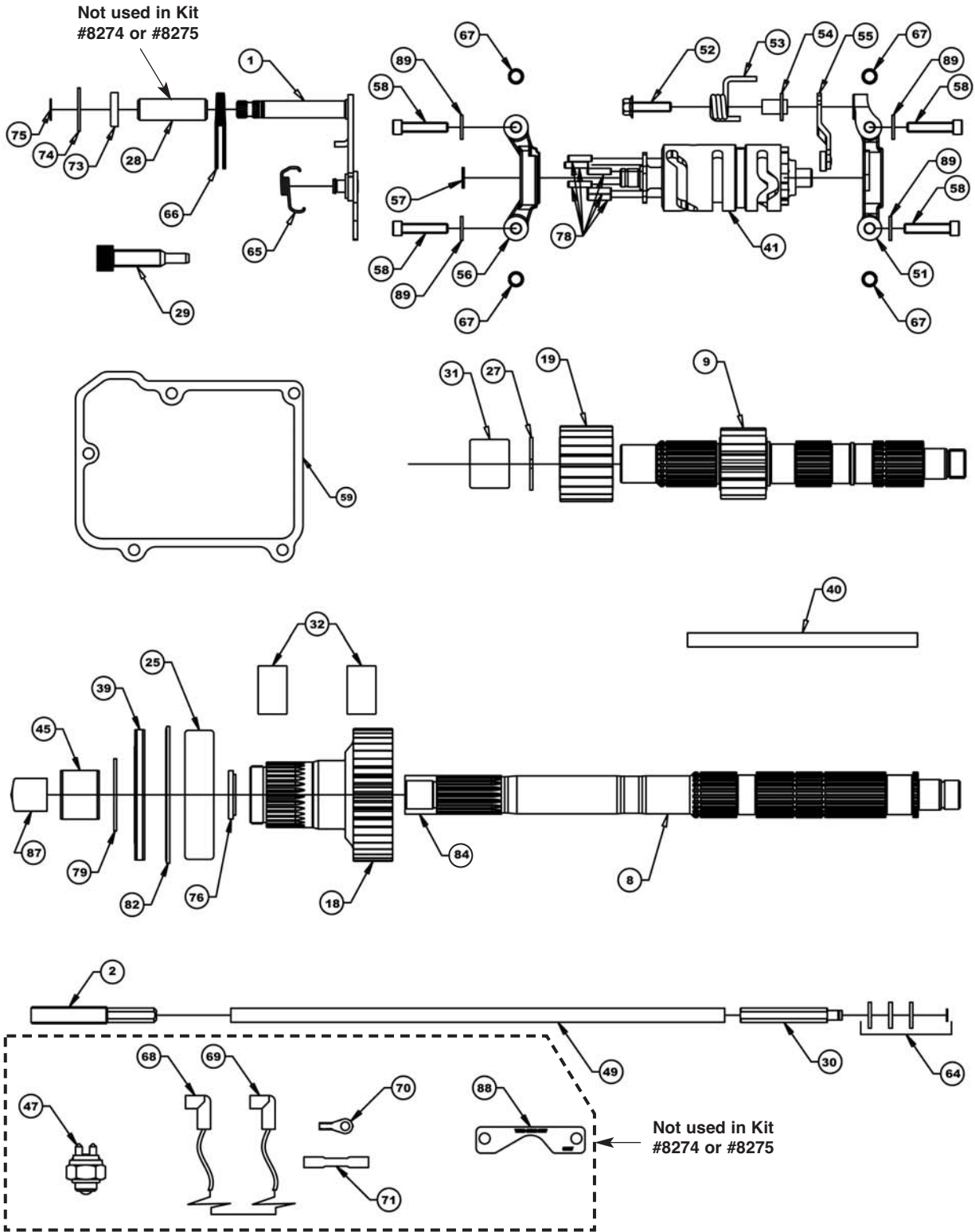
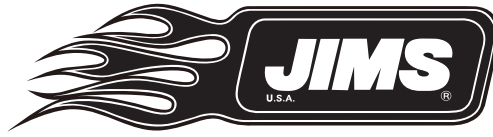

**CAUTION: WEAR SAFETY GLASSES. EXCESSIVE FORCE MAY DAMAGE PARTS!
SEE JIMS® CATALOG FOR HUNDREDS OF TOP QUALITY PROFESSIONAL TOOLS.
THE LAST TOOLS YOU WILL EVER NEED TO BUY.**

Performance Parts For Harley-Davidson Motorcycles

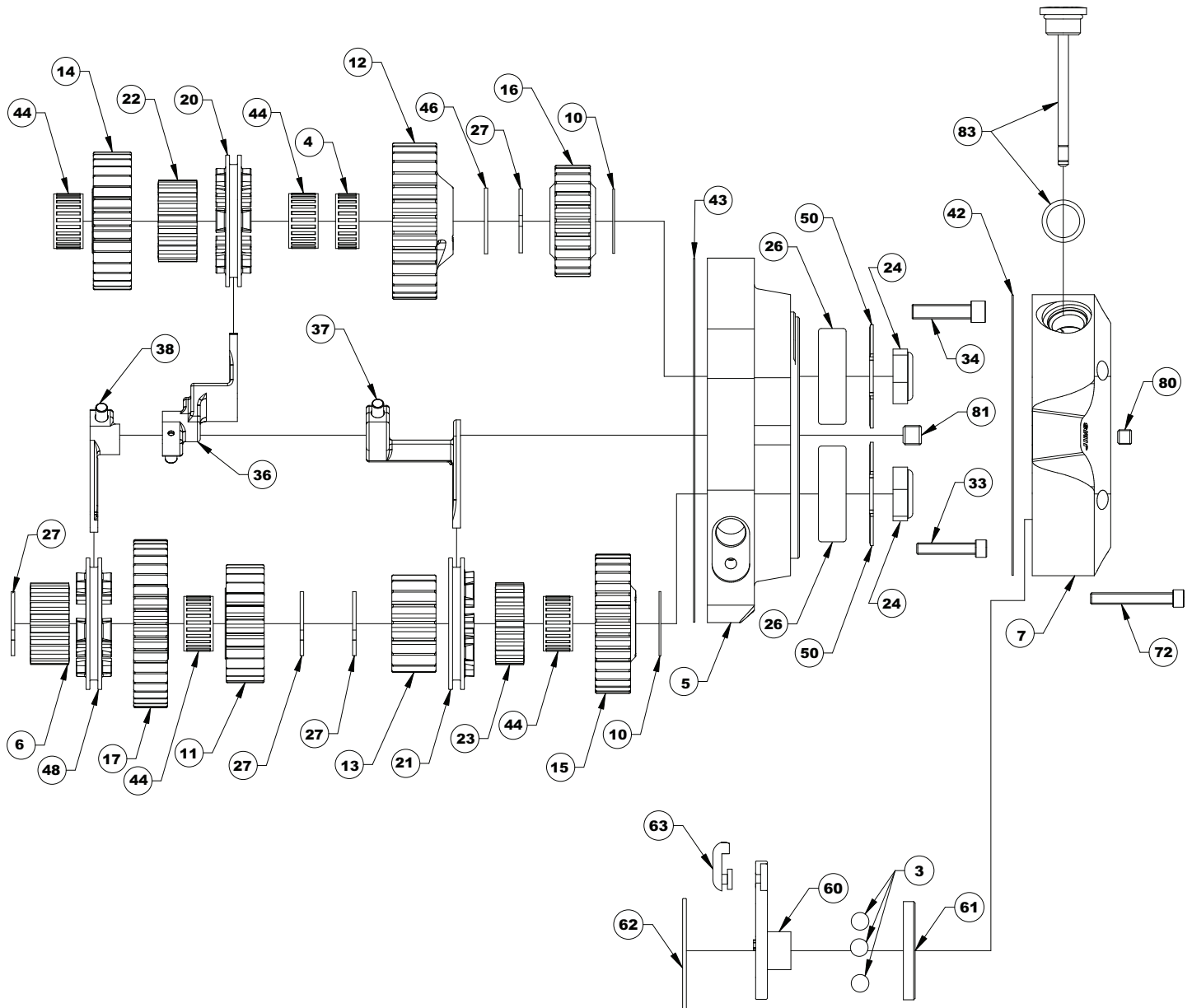
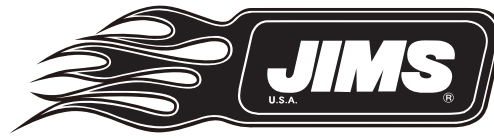

**CAUTION: WEAR SAFETY GLASSES. EXCESSIVE FORCE MAY DAMAGE PARTS!
SEE JIMS® CATALOG FOR HUNDREDS OF TOP QUALITY PROFESSIONAL TOOLS.
THE LAST TOOLS YOU WILL EVER NEED TO BUY.**

Performance Parts For Harley-Davidson® Motorcycles



Customer Support:

*For any installation on service or Questions, Please contact JIMS® Technical Department @
(805)-482-6913*

WARRANTY PROVISIONS

All JIMS® parts are guaranteed to the original purchaser to be free of manufacturing defects in materials and workmanship for a period of 12 (twelve) months from the date of purchase. Merchandise that fails to conform to these conditions will be repaired or replaced at JIMS® option if the parts are returned to us by the purchaser within the 12 (twelve) month warranty period or within 10 (ten) days thereafter.

In the event warranty service is required, the original purchaser must call or write JIMS® immediately with the problem. Some problems can be rectified by a telephone call and need no further course of action. A part suspected of being defective must not be replaced by a Dealer without prior authorization from JIMS®. If it is deemed necessary for JIMS® to make an evaluation to determine whether the part is defective, it must be packaged properly to prevent further damage and be returned prepaid to JIMS® with a copy of the original invoice of purchase and a detailed letter outlining the nature of the problem, how the part was used and the circumstances at the time of failure. If after an evaluation has been made by JIMS® and the part was found to be defective, repair, replacement or credit will be granted.

ADDITIONAL WARRANTY PROVISIONS

1. JIMS® shall have no obligation in the event a JIMS® part is modified by any other person or organization.
2. JIMS® shall have no obligation if a JIMS® part becomes defective in whole or in part as a result of improper installation, improper maintenance, improper use, abnormal operation, or any other misuse or mistreatment of the part.
3. JIMS® shall not be liable for any consequential or incidental damages resulting from the failure of a JIMS® part, the breach of any warranties, the failure to deliver, delay in delivery, delivery in non-conforming condition, or for any other breach of contract or duty between JIMS® and a customer.
4. JIMS® parts are designed exclusively for use in Harley-Davidson® motorcycles. JIMS® shall have no warranty or liability obligation if a JIMS® part is used in any other application.

DISCLAIMER

The words Harley, H.D.® is a registered trademark and is for reference only. Use of H.D.® model designations and part numbers are for reference only. JIMS® has no associations with, and makes no claims against, these words, trademarks, or companies.

The installation of these parts may void or otherwise adversely affect your factory warranty. It is the sole responsibility of the user to determine the suitability of this product for his or her use, and the user shall assume all legal, personal injury risk and liability and all other obligations, duties and risks associated therewith.

**CAUTION: WEAR SAFETY GLASSES. EXCESSIVE FORCE MAY DAMAGE PARTS!
SEE JIMS® CATALOG FOR HUNDREDS OF TOP QUALITY PROFESSIONAL TOOLS.
THE LAST TOOLS YOU WILL EVER NEED TO BUY.**

Performance Parts For Harley-Davidson® Motorcycles