

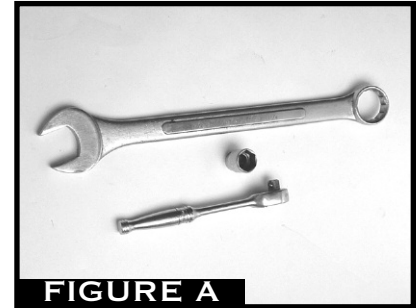

# INSTRUCTION SHEET FOR TOOL #2250

## PIVOT BEARING REMOVER AND INSTALLER

Use this tool when removing and installing the swingarm pivot bearing for 1984-Present Softails that use H.D.® No. 9076, or 9270A. This tool can also be used to remove and install front fender spherical bearings on Softail Springers 1997-2002 & 2004-Present that use H.D.® No. 9149.

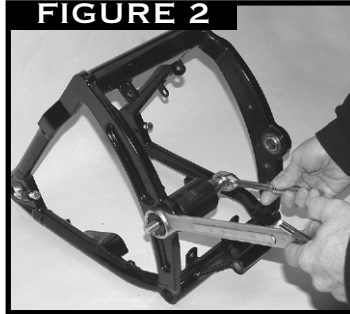
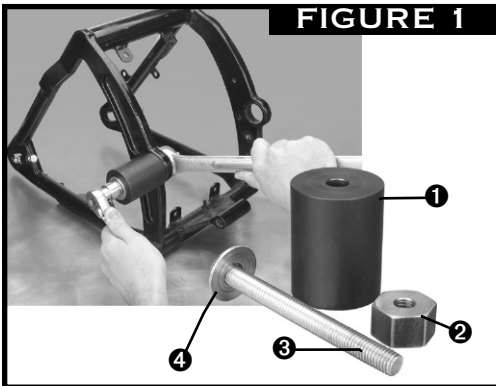

### TOOLS AND PRODUCTS NEEDED:

Tools (See Figure A) and product needed for replacing one set of swingarm pivot bearings or front fender spherical bearings: One 1-1/4" deep socket or wrench, One 3/4" socket and drive ratchet, A small amount of H.D.® 20w50 oil and new H.D.® Bearings.

### To Remove:

1. See the H.D.® Service manual for year and application to remove swingarm or Springer front fender.
2. Lube both sides of the washer (No. 2038) between the cup (No. 35316-80-1) and under the bolt head and threads of bolt (No. 1237) with H.D.® 20w50 oil.

### For Early model Softails 1984-1999 with retaining ring on the inside of the swingarm or Springer front fenders:

- 3A. From the inside of either the swingarm or the front fender, align the cup assembly around the bearing so that the bore in the cup (No.35316-80-1) locates around the retaining ring of the pivot bearing and the bolt (No. 1237) slides through the center of the cup and bearing race. (See Figures 2 & 5)

### For Late model Softails 2000-Present with retaining ring on the outside of the swingarm:

- 3B. From the outside of the swingarm, align the cup assembly around the bearing so that the bore in the cup (No.35316-80-1) locates around the retaining ring of the pivot bearing and the bolt (No.1237) slides through the center of the cup and bearing race. (See Figures 1 & 4)
4. Lube the threads of the bolt and I.D. threads of the end cap with H.D.® 20w50 oil. With the counterbore of the end cap (No. 2250-1) facing the bearing, thread the end cap (No. 2250-1) onto the bolt until snug while being sure to center the retaining ring of the bearing into the bore on the cup (No.35316-80-1).
5. While holding the end cap (No. 2250-1) using a 1-1/4" deep socket or wrench, tighten only bolt (No. 1237) using a 3/4" socket and ratchet so that the bearing is pulled free of the swingarm or fender and into the cup. **NOTE: (DISCARD OLD BEARING)**
6. Repeat steps 1-5 for the opposite side of the swingarm.

PARTS AVAILABLE SEPARATELY			
FIGURE 1 & 2 PARTS LIST			
NO.	QTY	DESCRIPTION	PART NO.
1	1	CUP	35316-80-1
2	1	END CAP	2250-1
3	1	HEX CAP BOLT	1237
4	2	WASHER	2038

**CAUTION: WEAR SAFETY GLASSES. EXCESSIVE FORCE MAY DAMAGE PARTS!**  
**SEE JIMS® CATALOG FOR HUNDREDS OF TOP QUALITY PROFESSIONAL TOOLS.**  
**THE LAST TOOLS YOU WILL EVER NEED TO BUY.**



## INSTRUCTION SHEET FOR TOOL #2250

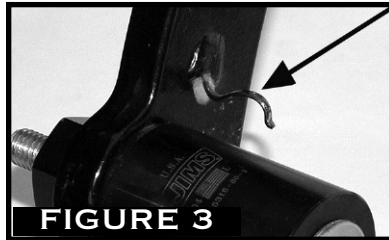

BRAKE LINE BRACKET

### **To Install:**

A) *Inspect and clean the bore in the swingarm or fender and remove any foreign material. Measure the bearing and bore to make sure there is at least a .001" press fit and a max of .002".*

B) *If needed, lightly lube the I.D. of bearing bore and the O.D. of the new bearing.*

1. Lube both sides of the washer (No. 2038), between the cup (No. 35316-80-1) and under the bolt head (No. 1237) and threads of bolt (No. 1237) with H.D.® 20w50 OIL.

### **For Early model Softails 1984-1999 with retaining ring on the inside of the swingarm:**

2A. Align the cup, washer and bolt assembly around the outside of the bearing bore, being sure that the bolt goes through the center of the bearing bore. Make sure that the cup is resting flat against the swingarm. (See *Figures 1 & 4*)

### **For Late model Softails 2000-Present with retaining ring on the outside of the swingarm:**

2B. Align the cup, washer and bolt assembly around the inside of the bearing bore, being sure that the bolt goes thru the center of the bearing bore. Make sure the cup is resting flat against the swing arm. In some cases a weld holding the bracket for the brake line will keep a small portion of the cup up and away from the swingarm. If necessary use a belt sander or grinder to relieve the cup (No. 35216-80-1) in this area to clear the weld. (See *Figures 3 & 5*)

4. Lube the threads of the bolt and I.D. threads of the end cap with H.D.® 20w50 oil. With the counterbore of the end cap facing the bearing, thread the end cap onto the bolt until snug. Be sure to center the bearing, cup and end cap assembly into the bore of the swingarm so that the bearing is going in straight.

5. While holding the end cap using a 1-1/4" deep socket or wrench, tighten only the bolt (No.1237) using a 3/4" socket and ratchet until you feel strong resistance, (about 35 ft-lbs. of torque) and the pivot bearing is fully seated with the retaining ring flat against the swingarm.

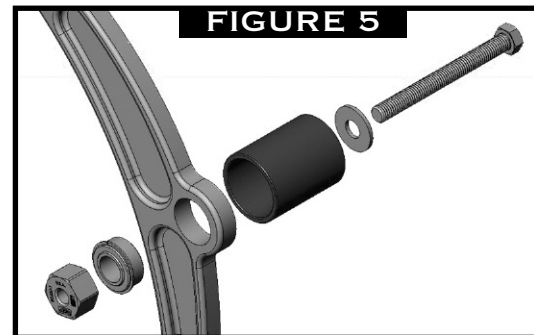
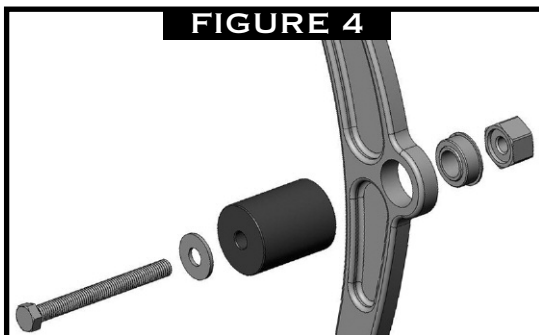

**CAUTION: WEAR SAFETY GLASSES. EXCESSIVE FORCE MAY DAMAGE PARTS!  
SEE JIMS® CATALOG FOR HUNDREDS OF TOP QUALITY PROFESSIONAL TOOLS.  
THE LAST TOOLS YOU WILL EVER NEED TO BUY.**