



INSTRUCTION SHEET FOR TOOL #990

CAM ASSEMBLY TOOL

USE ON ALL DYNA MODELS 2006 TO PRESENT

This tool will make ease of installing cams, secondary cam chain, and assist in proper cam alignment for installation in cam chest.

Read complete instruction sheet before performing task.

Refer to 2006 and later Dyna H.D. service manual for performing cam chest service work.

When you are about to install a set of cams back into the motor go to step 1.

1. Take your rear cam #4 and place it into left hole of tool base plate #1 with crankcase side of cam installed in hole. Place cap #3 on end of camshaft as shown in Fig.2.
2. Install front cam #5 in the right base plate hole with cam installed in same direction as rear cam. Place cap #2 on end of camshaft as shown in Fig.2. When doing this, you also need to install your secondary cam chain #6 onto both camshaft sprockets. **Note:** Remember to place chain back onto cam sprockets in the same direction as previously run per H.D. service manual in disassembly instructions. At the same time your installing the chain, you will need to line up the cam timing marks on the teeth of each cam to face each other at center as shown in Fig 2.

3. Now place cam support plate over delrin caps and onto camshafts as shown in Fig. 1. Then remove the two caps #2 & #3 and confirm that you have good cam alignment with alignment marks on end of camshafts with a straight edge as shown in Fig 3.
4. If alignment is correct then refer to H.D. service book for installing front variable cam spacer, retainer and the remaining cam installation instructions.

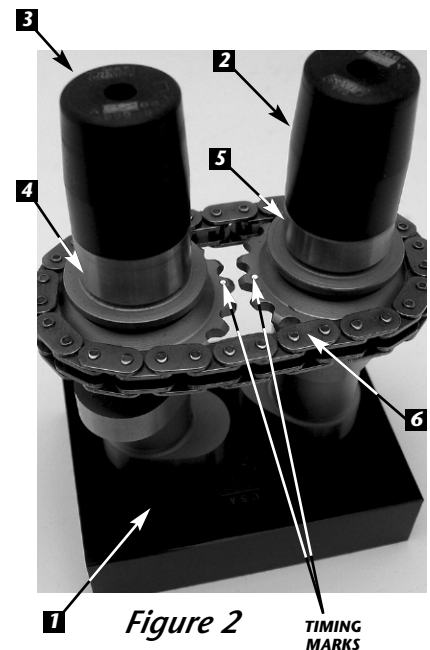
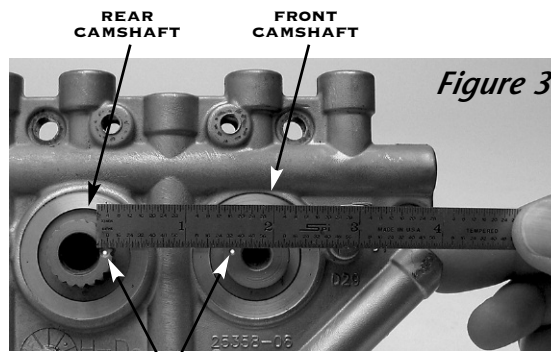
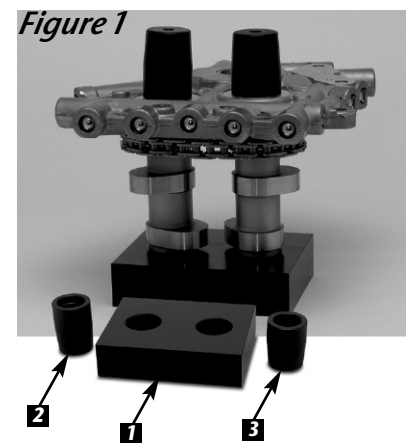

PARTS AVAILABLE SEPARATELY

No.	Qty.	Description	Part No.
1	1	BASE	990-1
2	1	FRONT GUIDE	990-2
3	1	REAR GUIDE	990-3
4	1	INSTRUCTION SHEET	990-IS

**CAUTION: WEAR SAFETY GLASSES. EXCESSIVE FORCE MAY DAMAGE PARTS!
SEE JIMS® CATALOG FOR HUNDREDS OF TOP QUALITY PROFESSIONAL TOOLS.
THE LAST TOOLS YOU WILL EVER NEED TO BUY.**

Performance Parts For Harley-Davidson® Motorcycles