



**INSTRUCTION SHEET FOR TOOL #971**

**CLUTCH BEARING ASSEMBLY SERVICE TOOL**

USE ON 1990 TO PRESENT BIG TWINS



**JIM'S TOOLS NEEDED TO PERFORM THIS SERVICE:**

- 1) Tools No.2316, 2317 or 2234 primary drive locking bar tools, depending on year and model.
- 2) Tool No.38515-90, clutch spring compressor, 1990 to 1997.
- 3) Tool No.1030-TS, 1-1/2" socket to remove front compensating nut (bolt) on most early models.

Other helpful hand tools:

- 1) 3/4" Wrench for primary drain bolt on most early models or T-40 Torx wrench. For primary drain screw on most late models big twins.
- 2) 3/16" Allen wrench, for primary cover screws on most years.
- 3) 9/16" Socket primary adjuster used on most early models and 1/2" socket used on most late models also 8" wire tie.
- 4) 3/4" Socket to remove front compensating nut (bolt) on most late models.
- 5) 1-3/16" Socket to remove the clutch hub nut, on Big Twin all models.
- 6) 8mm Socket to remove the starter shaft bolt.

**PARTS AVAILABLE SEPARATELY**

No.	Qty.	Description	Part No.
1	1	Bearing Remover/Installer	971-3
2	1	Inner Hub Remover/Installer	971-4
3	1	Clutch Hub Installer	971-5
4	1	Clutch Hub Bearing Pedestal	971-6

**NOTE: PLEASE READ ALL INSTRUCTIONS COMPLETELY BEFORE PERFORMING ANY WORK!IF YOU DO NOT KNOW WHAT YOU ARE DOING, DO NOT DO IT!**

No information in this instruction sheet pertaining to motorcycle repair is represented as foolproof or even altogether safe. Even something safe, done incorrectly or incompletely can and will backfire. You and only you are responsible for the safety of your repair work and for your understanding the application and use of repair equipment, components, methods and concepts. Each and every step that this tool is designed to do must be carefully and systematically performed safely by you. All information listed in this instruction sheet has been tested, re-tested and used daily in JIMS® Research and Development Department.

**ALWAYS WEAR SAFETY GLASSES OR OTHER FACE AND EYE PROTECTION SUCH AS FULL FACE SHIELD. JIMS® IS NOT RESPONSIBLE FOR DAMAGE , INJURY, OR YOUR WORK. JIMS® IS NOT RESPONSIBLE FOR THE QUALITY AND SAFETY OF YOUR WORK.**

CAUTION: WEAR SAFETY GLASSES. EXCESSIVE FORCE MAY DAMAGE PARTS!  
SEE JIMS® CATALOG FOR HUNDREDS OF TOP QUALITY PROFESSIONAL TOOLS.  
THE LAST TOOLS YOU WILL EVER NEED TO BUY.

*Performance Parts For Harley-Davidson® Motorcycles*

## INSTRUCTION SHEET FOR TOOL #971



Fig. 1

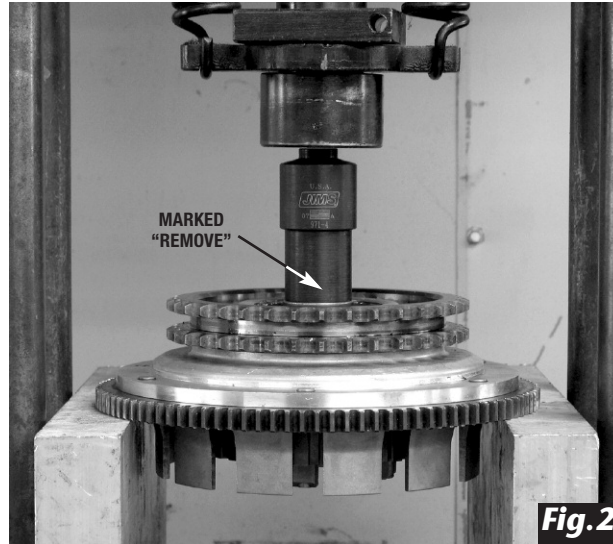

Fig. 2



Fig. 3

### Disassembly Procedures

**Warning: Disconnect the negative ground cable at the battery**

1. Disassemble clutch per H-D service manual for appropriate year and model for the motorcycle you will be repairing.
2. Remove retaining ring H-D No.37904-90 from inner clutch hub. See Fig 1.
3. Support clutch shell with the side you removed retaining ring from, facing up on the press using suitable blocks, to raise up approximately 6". The clutch shell needs enough space to remove the inner clutch hub.
4. Place hub remover tool No.2 with laser mark "REMOVE" end on clutch hub spud side into the spline bore. See Fig 2.
5. Align with press ram and remove clutch hub from shell.
6. Remove the bearing retaining ring from the inside of the clutch shell. See Fig 3.
7. Turn over clutch shell and place No.1 bearing remover tool with side laser marked "REMOVE" into bearing and press bearing out of the clutch shell. See Fig 4.

### Assembly Procedures

8. Place No.4, clutch shell pedestal on the press with shallow recessed side facing up. Place the clutch shell on pedestal stand so that the bearing bore area sits squarely on the pedestal. See Fig 5.
9. Clean all surfaces and apply press lube to both the clutch shell bearing mounting surface and to clutch bearing O.D. Position the new bearing

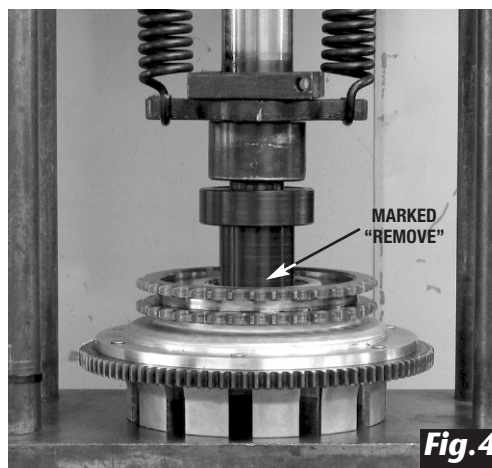

Fig. 4

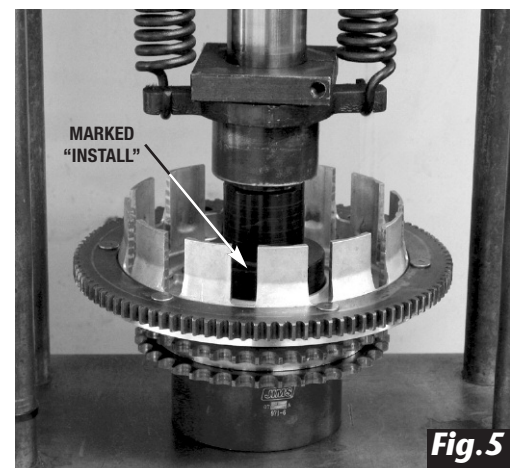

Fig. 5

**CAUTION: WEAR SAFETY GLASSES. EXCESSIVE FORCE MAY DAMAGE PARTS!**  
 SEE JIMS® CATALOG FOR HUNDREDS OF TOP QUALITY PROFESSIONAL TOOLS.  
 THE LAST TOOLS YOU WILL EVER NEED TO BUY.

*Performance Parts For Harley-Davidson® Motorcycles*

## INSTRUCTION SHEET FOR TOOL #971

on clutch shell and place No.1 bearing installer tool with laser marked "INSTALL" side facing bearing and shell. Line up ram and press bearing into the clutch shell. See Fig 5.

10. Install a new retaining ring.

11. Place No.3, clutch hub installer tool onto the press with the small end up and place the clutch shell with lubed I.D.of bearing on top of No.3, making sure the bearing sits squarely on the tool.

12. Lube press surface of clutch hub and place onto the small spud of No.3 of the hub installer tool directly over the bearing. Place No.2, hub installer tool with laser marked "INSTALL" side facing the clutch shell lined up over press ram and clutch hub. Press hub into bearing and install retaining ring. See Fig 6.

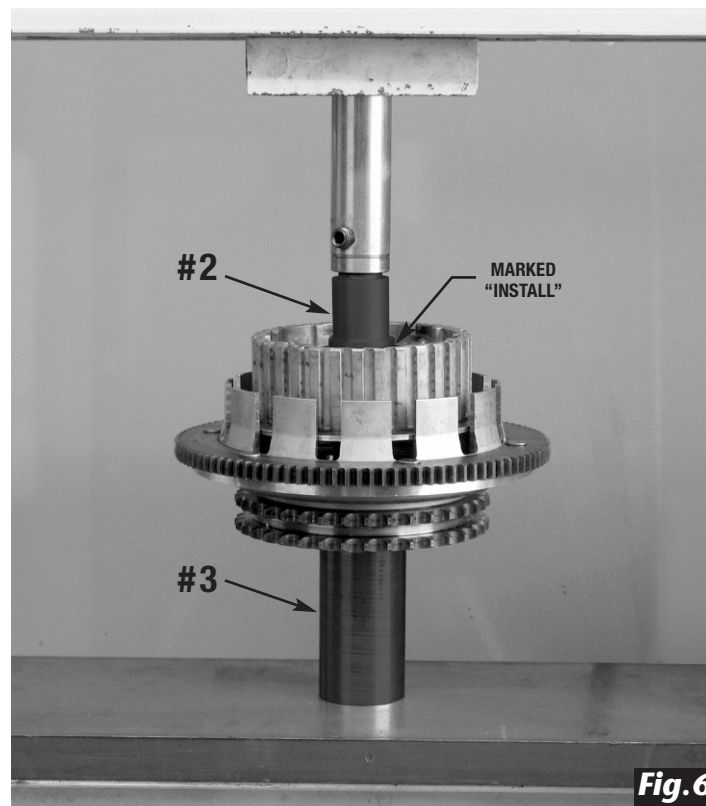

**CAUTION: WEAR SAFETY GLASSES. EXCESSIVE FORCE MAY DAMAGE PARTS!**  
SEE JIMS® CATALOG FOR HUNDREDS OF TOP QUALITY PROFESSIONAL TOOLS.  
THE LAST TOOLS YOU WILL EVER NEED TO BUY.

*Performance Parts For Harley-Davidson® Motorcycles*